

# DECK SUPPLY SERVICES LLC TEST REPORT

**SCOPE OF WORK**

ICC-ES AC273 PERFORMANCE TESTING ON 1-7/8 IN ALUMINUM SURFACE POST TOWER MOUNT

**REPORT NUMBER**

H7830.01-119-19-R0

**TEST DATE(S)**

03/28/18

**ISSUE DATE**

08/07/18

**RECORD RETENTION END DATE**

03/28/22

**PAGES**

14

**DOCUMENT CONTROL NUMBER**

ATI 00645 (07/24/17)

RT-R-AMER-Test-2794

© 2017 INTERTEK

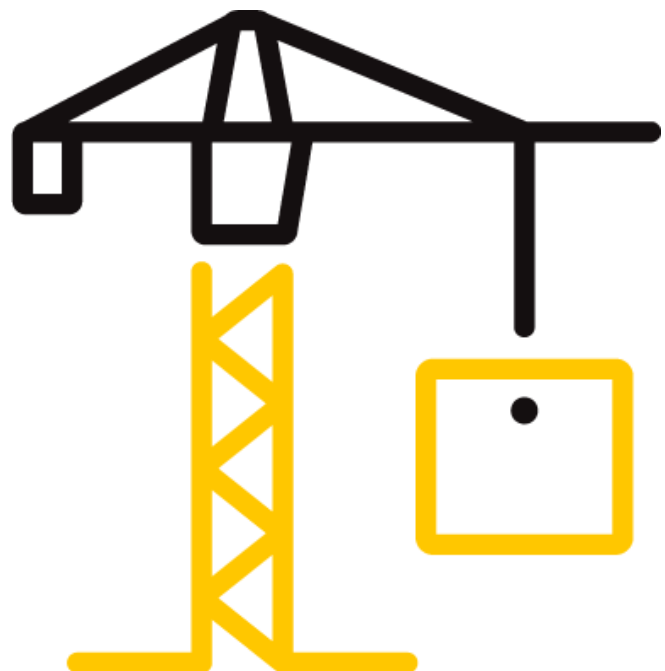

## TEST REPORT FOR DECK SUPPLY SERVICES LLC

Report No.: H7830.01-119-19-r0

Date: 08/07/18

### REPORT ISSUED TO

#### DECK SUPPLY SERVICES LLC

3977 160<sup>th</sup> Street

Blue Grass, IA 52726

### SECTION 1

#### SCOPE

Intertek Building & Construction (B&C) was contracted by Deck Supply Services LLC, Blue Grass, IA 52726 to perform structural performance tests in accordance with Section 4.3 of ICC-ES™ AC273 on their 1-7/8 in aluminum surface post tower mount. Results obtained are tested values and were secured by using the designated test method(s). Testing was conducted at the Intertek B&C test facility in York, PA.

Intertek B&C in York, Pennsylvania has demonstrated compliance with ISO/IEC International Standard 17025 and is consequently accredited as a Testing Laboratory (TL-144) by International Accreditation Service, Inc. (IAS). Intertek B&C is accredited to perform all testing reported herein.

This report does not constitute certification of this product nor an opinion or endorsement by this laboratory.

For INTERTEK B&C:

<b>COMPLETED BY:</b>	Alva R. Baker
<b>TITLE:</b>	Technician III
<b>SIGNATURE:</b>	 <small>Digitally Signed for: Alva Baker by Amanda Ashby</small>
<b>DATE:</b>	08/07/18

ARM:vtm/aaa

<b>REVIEWED BY:</b>	V. Thomas Mickley, Jr., P.E.
<b>TITLE:</b>	Senior Staff Engineer
<b>SIGNATURE:</b>	 <small>Digitally Signed by: Virgal Thomas Mickley, Jr.</small>
<b>DATE:</b>	08/07/18

This report is for the exclusive use of Intertek's Client and is provided pursuant to the agreement between Intertek and its Client. Intertek's responsibility and liability are limited to the terms and conditions of the agreement. Intertek assumes no liability to any party, other than to the Client in accordance with the agreement, for any loss, expense or damage occasioned by the use of this report. Only the Client is authorized to permit copying or distribution of this report and then only in its entirety. Any use of the Intertek name or one of its marks for the sale or advertisement of the tested material, product or service must first be approved in writing by Intertek. The observations and test results in this report are relevant only to the sample(s) tested. This report by itself does not imply that the material, product, or service is or has ever been under an Intertek certification program.

## TEST REPORT FOR DECK SUPPLY SERVICES LLC

Report No.: H7830.01-119-19-r0

Date: 08/07/18

### SECTION 2

#### TEST METHOD(S)

The specimens were evaluated in accordance with Section 4.3 of the following:

**ICC-ES™ AC273 (June, 2017), Acceptance Criteria for Handrails and Guards**

ICC-ES™ AC273 was developed by the ICC Evaluation Service, Inc. (ICC-ES™) as acceptance criteria to evaluate compliance with the following building codes:

2015 *International Building Code*®, International Code Council

2015 *International Residential Code*®, International Code Council

#### Limitations

Anchorage of support posts to the supporting structure is not included in the scope of this testing and would need to be evaluated separately.

Testing is limited to satisfying the IRC - One- and Two-Family Dwellings requirements of ICC-ES™ AC273.

### SECTION 3

#### MATERIAL SOURCE

All materials utilized for testing reported herein were provided to Intertek B&C by Deck Supply Services LLC and were not sampled or selected by an independent inspection agency. Representative samples of the test specimen(s) will be retained by Intertek B&C for a minimum of four years from the test completion date.

Test specimens were inspected prior to testing to verify the condition of the materials was suitable for testing. No potentially compromising defects were observed.

### SECTION 4

#### LIST OF OFFICIAL OBSERVERS

NAME	COMPANY
Alva R. Baker	Intertek B&C

**TEST REPORT FOR DECK SUPPLY SERVICES LLC**

Report No.: H7830.01-119-19-r0

Date: 08/07/18

**SECTION 5****TEST PROCEDURE**

Post mount tests were performed per ICC-ES™ AC273, Section 4.3 in a self-contained structural frame designed to accommodate anchorage of a rail assembly and application of the required test loads. The specimens were loaded using an electric winch mounted to a rigid steel test frame. High strength steel cables and nylon straps were used to impose test loads on the specimens. Applied load was measured using an electronic load cell located in-line with the loading system. Deflections were measured to the nearest 0.01 in using electronic linear displacement transducers.

The post mount assembly was installed and tested by directly securing (surface-mounting) the base of the post mounts to a rigid steel test frame (simulated concrete). The post mount to base plate attachment screws were located such that the line of screws was perpendicular to the direction of the applied load (reference Photo No. 4 in Section 9). Transducers mounted to an independent reference frame were located at the top of the post mount, adjacent to the load application strap to record movement of reference points on the post mount. See photographs in Section 9 for test setups.

The test specimen was inspected prior to testing to verify size and general condition of the materials, assembly, and installation. No potentially compromising defects were observed. One specimen was used for all load tests which were performed in the order reported. Each design load test was performed using the following procedure:

1. Zeroed transducers and load cell at zero load;
2. Increased load to specified test load in no less than ten seconds; and
3. Increased load to failure.

Unless otherwise noted, all loads and displacement measurements were normal to the post tower (horizontal).

## TEST REPORT FOR DECK SUPPLY SERVICES LLC

Report No.: H7830.01-119-19-r0

Date: 08/07/18

### SECTION 6

#### TEST SPECIMEN DESCRIPTION

The surface post tower mount is comprised of an aluminum post. Drawings are included in Section 10 to verify the overall dimensions and other pertinent information of the tested product, its components, and any constructed assemblies. Photographs are provided in Section 9.

<b>PRODUCT</b>	Aluminum Post Tower Mount (Surface Mount)
<b>POST</b>	1-7/8 in square by 0.105 in thick wall 6005-T5 aluminum extrusion with six raceway channels
<b>BASE PLATE</b>	3-13/16 in square by 1/2 in thick 6005-T5 aluminum plate with four 13/32 in wide by 17/32 in long slotted holes, two 1/4 in diameter holes and four 7/32 in diameter holes
<b>OVERALL HEIGHT</b>	39-1/4 in (bottom of base plate to top of post)

#### Fastening Schedule

<b>CONNECTION</b>	<b>FASTENER</b>
Post to Base Plate <sup>1</sup>	1/4 in continuous fillet weld all around; Four #10-24 x 1-1/2 in (0.187 major diameter) T-15 star drive, trim head, type C point, coated steel screws; Two 1/4-20 x 2 in (0.247 major diameter) T-30 star drive, trim head, type F point, coated steel screws
Post Mount to Substructure	Four 1/2 in Grade 8 hex-head bolts with washer

<sup>1</sup> The post mount to base plate attachment screws were located such that the line of screws was perpendicular to the direction of the applied load. Reference Photo No. 4 in Section 9 for test load direction.

## TEST REPORT FOR DECK SUPPLY SERVICES LLC

Report No.: H7830.01-119-19-r0

Date: 08/07/18

### SECTION 7

#### TEST RESULTS

##### Key to Test Results Tables:

Load Level: Target test load

Test Load: Actual applied load at the designated load level (target).

Elapsed Time (E.T.): The amount of time into the test with zero established at the beginning of the loading procedure.

##### Test No. 1 - Test Date: 03/28/18

Design Load: 200 lb Concentrated Load at Top of Post Mount (36 in High)

LOAD LEVEL	TEST LOAD (lb)	E.T. (min:sec)	DISPLACEMENT (in)
200 lb (D.L.)	201	00:22	1.17
Ultimate Load	610	01:05	<b>Mode of Failure:</b> Weld cracked and bottom screws pulled out

##### Deflection Evaluation:

Maximum post deflection at 201 lb = 1.17 in

Limits per AC273:

$$\frac{h}{12} = \frac{36}{12} = 3.0" > 1.17 \therefore ok$$

##### Test No. 2 - Test Date: 03/28/18

Design Load: 200 lb Concentrated Load at Top of Post Mount (36 in High)

LOAD LEVEL	TEST LOAD (lb)	E.T. (min:sec)	DISPLACEMENT (in)
200 lb (D.L.)	202	00:14	1.17
Ultimate Load	582	00:47	<b>Mode of Failure:</b> Weld cracked and bottom screws pulled out

##### Deflection Evaluation:

Maximum post deflection at 202 lb = 1.17 in

Limits per AC273:

$$\frac{h}{12} = \frac{36}{12} = 3.0" > 1.17 \therefore ok$$

## TEST REPORT FOR DECK SUPPLY SERVICES LLC

Report No.: H7830.01-119-19-r0

Date: 08/07/18

**Test No. 3 - Test Date: 03/28/18**

**Design Load: 200 lb Concentrated Load at Top of Post Mount (36 in High)**

LOAD LEVEL	TEST LOAD (lb)	E.T. (min:sec)	DISPLACEMENT (in)
200 lb (D.L.)	205	00:21	1.12
Ultimate Load	652	01:03	<b>Mode of Failure:</b> Weld cracked

### Deflection Evaluation:

Maximum post deflection at 205 lb = 1.12 in  
Limits per AC273:

$$\frac{h}{12} = \frac{36}{12} = 3.0" > 1.12 \therefore ok$$

### Test Summary

SPECIMEN NO.	ULTIMATE LOAD (LB)	DEVIATION FROM AVERAGE
1	610	-0.8%
2	582	-5.4%
3	652	6.0%
<b>AVERAGE</b>	<b>615</b>	

## SECTION 8

### CONCLUSION

When installed in a surface mounted condition to a concrete base, the post mount assembly reported herein meets the structural performance requirements of Section 4.3 of ICC-ES™ AC273 for use in One- and Two-Family Dwellings (IRC).

Anchorage of support posts to the supporting structure is not included in the scope of this testing and would need to be evaluated separately.

## TEST REPORT FOR DECK SUPPLY SERVICES LLC

Report No.: H7830.01-119-19-r0

Date: 08/07/18

### SECTION 9

### PHOTOGRAPHS



**Photo No. 1**  
**Static Post Load Test**



**Photo No. 2**  
**Static Post Load Test - Load Applied**

## TEST REPORT FOR DECK SUPPLY SERVICES LLC

Report No.: H7830.01-119-19-r0

Date: 08/07/18



**Photo No. 3**  
**Typical Failure at Weld on Base Plate**

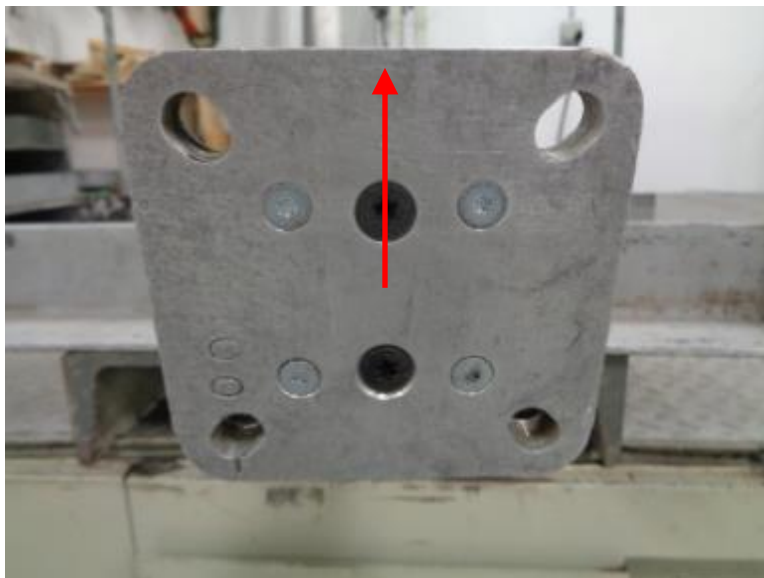

**Photo No. 4**  
**Connection at Bottom of Base Plate**  
**(Arrow Denotes Direction of Load)**



Total Quality. Assured.

130 Derry Court  
York, Pennsylvania 17406

Telephone: 717-764-7700  
Facsimile: 717-764-4129  
[www.intertek.com/building](http://www.intertek.com/building)

## TEST REPORT FOR DECK SUPPLY SERVICES LLC

Report No.: H7830.01-119-19-r0

Date: 08/07/18

### SECTION 10

#### DRAWINGS

The "As-Built" drawings for the 1-7/8 in aluminum surface post tower mount, which follow, have been reviewed by Intertek B&C and are representative of the project reported herein. Project construction was verified by Intertek B&C per the drawings included in this report. Any deviations are documented herein or on the drawings.

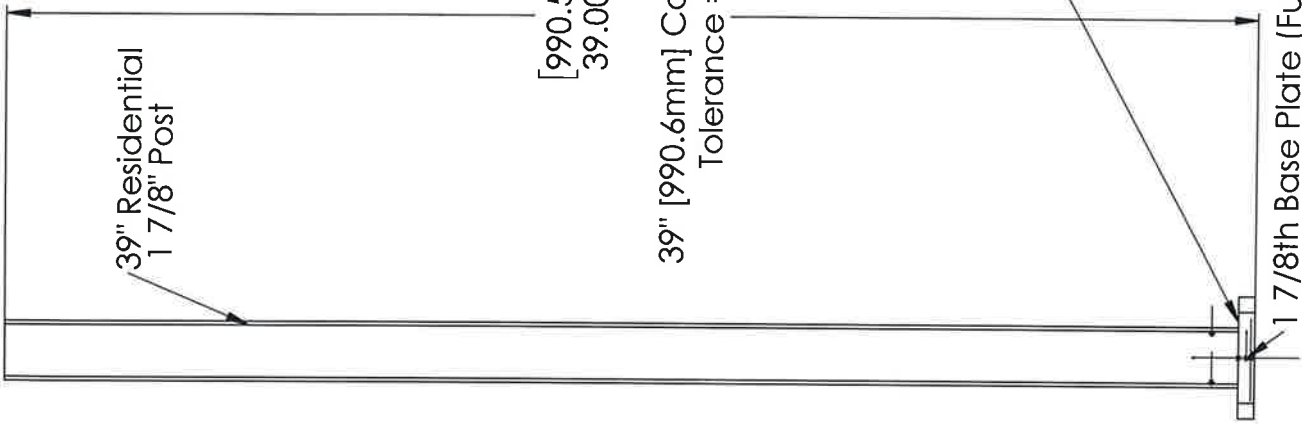

**DETAIL A**  
SCALE 1:2

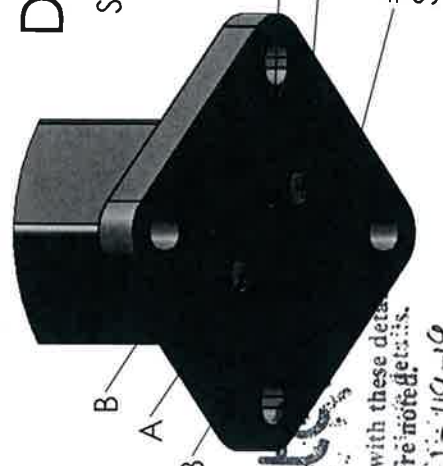

2"  
#14 SS Screws 1.5"  
SIM. "A"  
#8 SS Screws 1.5"  
SIM. "B"

**intertek**  
Test sample complies with these details.  
Deviations are noted as follows.  
Report # H7830.01-119-19  
Date 5-4-18 Tech ARB

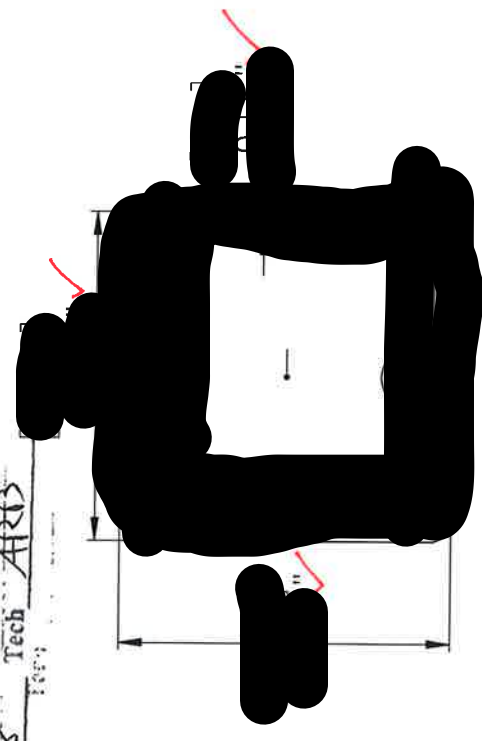

NAME	DATE
DRAWN	3/30/18
SIGNATURE	ALC
CHK'D	
APP'VD	
MFG	
Q.A	
TITLE: 39" Residential 1 7/8" Post Assembly	
DWG. NO.	
A4	
SCALE: 1:10	SHEET 1 OF 1

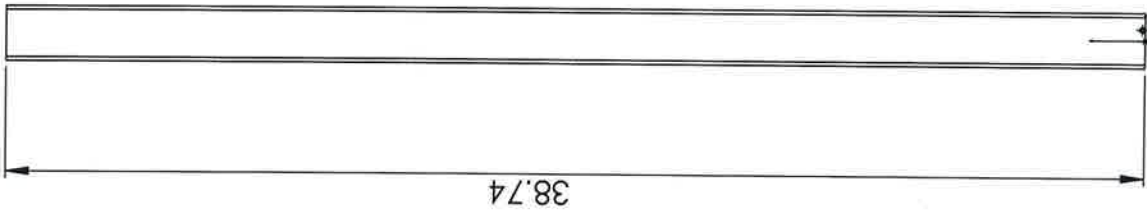

38.74

**intertek**

Test sample complies with these details.  
Deviations are noted.

Report # H7830.01-19-19

Date 5-4-18 Tech ARB

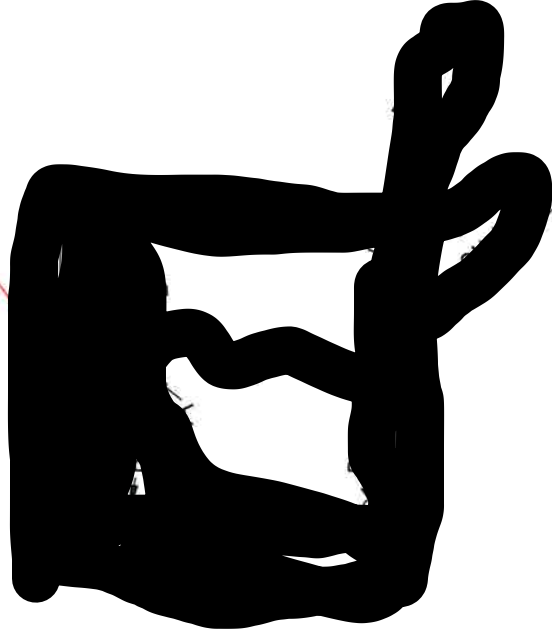

NAME	DATE	
DRAWN	3/30/18	
SIGNATURE	ALC	TITLE:
CHKD		39" Residential 1 7/8" Level Post
APPVD		
MFG		
Q/A		
DWG NO.		A4
SCALE: 1:10		SHEET 1 OF 1

Material: 6005-T5 ALUMINIUM

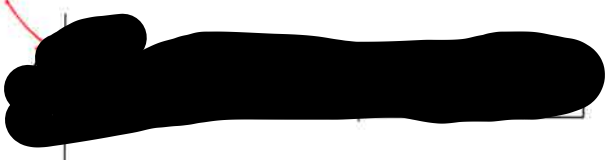
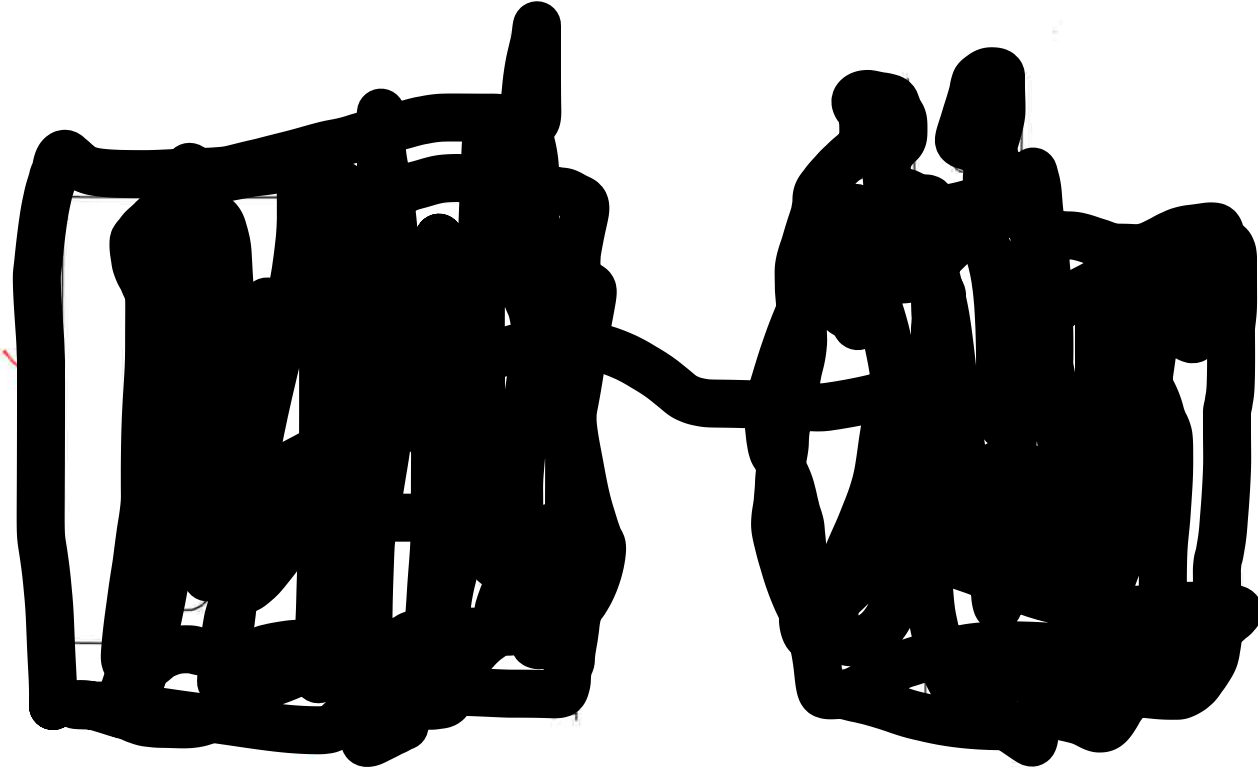

**intertek**

Test sample complies with these details.  
Deviations are noted.

Report # H7830.01-119-19

Date 5-4-16 Tech ARB

AAAP101: W005-T5 ALUMINUM

NAME	DATE	
DRAWN	3/30/18	
SIGNATURE	ALC	TITLE
CHKD		1.875" Post Base Plate (Full Screws)
APPVD		
MFG		
QA		
DWG NO.		A4
SCALE:1:2		SHEET 1 OF 1



Total Quality. Assured.

130 Derry Court  
York, Pennsylvania 17406

Telephone: 717-764-7700  
Facsimile: 717-764-4129  
[www.intertek.com/building](http://www.intertek.com/building)

## TEST REPORT FOR DECK SUPPLY SERVICES LLC

Report No.: H7830.01-119-19-r0

Date: 08/07/18

### SECTION 11

#### REVISION LOG

REVISION #	DATE	PAGES	REVISION
0	08/07/18	N/A	Original Report Issue